

EMBALMING STATIONS ARE AVAILABLE IN LEFT OR RIGHT HAND CONFIGURATIONS
 LOW LEVEL BOWL OR FLUSHING SLUICE OPTION

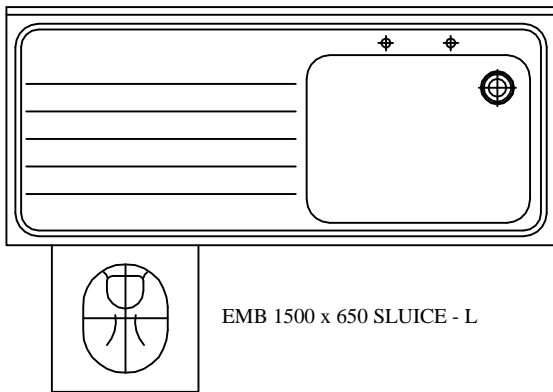
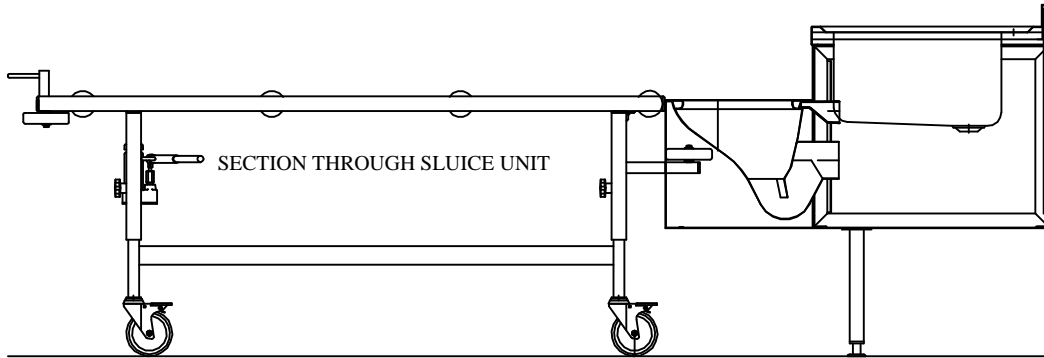

EMB 1500 x 650 SLUICE - L

FITTINGS PROVIDED - all models

15mm Pillar type H/C lever mixer tap chromium plated.
 Standup type stainless steel strainer waste, with bowl fitting.
 Trigger action spray attachment with retaining hook.
 3000mm of 15mm smooth flexible hose.
 Thermostatic fail-safe mixing valve.

7.5 litre capacity remote cisterns are provided with sluice units.

THIS MODEL AVAILABLE WITH INTEGRAL:-

Water Heater.
 Pumped Sluice.
 Break Tank with type A airgap.

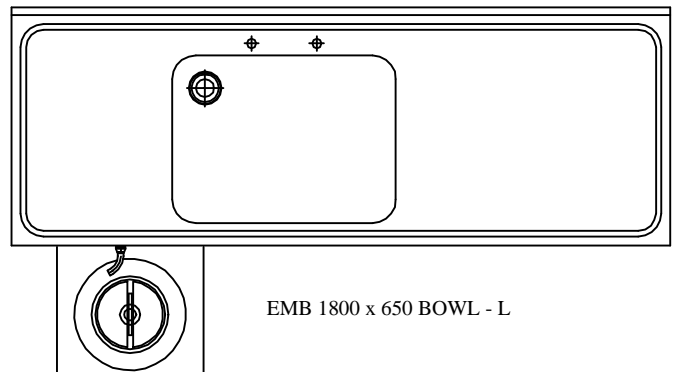

EMB 1800 x 650 BOWL - L

